

UNIDRIVE M400



MINIMISE DOWNTIME & SYSTEM SETUP

0.25 - 132 kW (0.33 - 200 hp)
100 V | 200 V | 400 V | 575 V | 690 V

Unidrive M400 Highlights

- Reduced system costs with direct integration
- Fast and easy access for commissioning, monitoring and diagnostics
- Flexible communications
- Energy efficiency
- High performance open-loop control of induction motors

KEY FUNCTIONS

Function	Function	Function
Jog	✓	Supply loss detection
Bi-polar reference	✓	Low DC link operation
Pre-set speeds	8	Analogue input control
Pre-set timer	✓	Analogue output control
Skip frequencies	3	Temperature monitoring
Skip frequency dead bands	✓	Digital input control
Local/Remote	✓	Digital I/O programmable control
S-Ramp	✓	Relay control
Acceleration Rates	8	Mechanical Brake Controller
Deceleration Rates	8	Keypad button assignment
Pulse train frequency reference	0 - 100kHz	Motorised pot
Torque reference	✓	Logic function control
Remote keypad with real time clock	✓	Timer function control
Control mode: open loop vector mode	✓	Stop mode: Ramp
Control mode: fixed V/F mode	✓	Stop mode: Coast
Control mode: square V/F mode	✓	Stop mode: Fast Ramp
Control mode: RFC-A mode	✓	PID Control
On-board 'Scope function	✓	Limit switch control
Stator resistance compensation	✓	Variable selector
Slip compensation	✓	Energy meter
Auto-tune static	✓	Trip time stamping
Trip logging	✓	Run time log
Auto-tune rotating	✓	Control word control
Catch a spinning motor	✓	Auto reset
DC injection braking	✓	Cloning
Programmable braking	✓	On-board PLC
Motor Pre-heat control	✓	Additional Application parameters
Speed feedback via options	✓	Second motor set-up

SPECIFICATION

Unidrive M400

Items supplied with the drive	Step-By-Step Guide, Safety Information, Grounding bracket (Frames 1 to 4), Surface mounting brackets (frame 5 to 9)
Storage temperature	-40°C to 60°C, -4°F to 140°F
Operating temperature without de-rate	-20°C to 40°C, -4°F to 140°F
Operating temperature with de-rate	40°C to 60°C, 104°F to 140°F Frames 1 to 4 40°C to 55°C, 104°F to 131°F Frames 5 to 9
Supply requirements	Maximum supply imbalance: 2 % negative phase sequence (equivalent to 3 % voltage imbalance between phases). Input frequency 45 to 66Hz
Switching frequency range	*0.66,*1,2,3,4,6,8,12,16kHz (Factory default = 3kHz)
Approvals	CE (European Union), cUL Listed (USA and Canada), DNV (marine applications), KC (Korea), RCM (Australia/ New Zealand), EAC (Russian Customs Union)
Product safety standard	EN61800-5-1
Functional safety (Dual STO function)	TÜV certified
Altitude	1000m – No de-rate. 1000m to 3000m - 1% de-rate/100m
Humidity	95% Non-condensing
Pollution	Degree 2. Dry, non-conducting pollution only
IP Rating	IP20 – Pollution degree 2
Vibration	Reference standard IEC60068-2-27, IEC60068-2-29 bump test, IEC60068-2-64 random vibration test, IEC60068-2-6, EN61800-5-1 sinusoidal vibration test. Tested to Environmental Category ENV3.
Mounting methods	Frame 1 to 4 – Surface mount, DIN Rail or mounting holes Frame 5 to 9 – Surface mount or through-panel mount via mounting brackets
Output frequency/speed range	599Hz
Braking	In-built braking transistor, external resistor required.
Operating modes	Open-loop, RFC-A (enhanced open-loop performance)
Overload capability	Open-loop – 150% for 60s RFC-A 180% for 3s
Overvoltage category	Evaluated for OVC III.
Corrosive environments	Category C3 according to BS EN ISO 9223
Immunity Compliance	IEC61800-3, EN60800-6-2, IEC 61000-4-2, IEC 61000-4-3, IEC61000-4-4, IEC61000-4-5, IEC61000-4-6, IEC61000-4-8, IEC61000-4-11, IEC61000-6-1, IEC 61000-6-2.
Emission compliance	Capable of meeting the requirements of Equipment Category C3 without external filters or line reactors. Capable of meeting the requirements of Equipment Category C2 when installed with the recommended filters and line reactors. IEC61800-3, IEC61000-6-4, EN61000-3-2, EN61000-3-12, EN61000-3-3, EN12015
Cooling	Forced cooled
Safe Torque Off	Dual STO channels.
Communications	RS485, Modbus RTU SI Options: EtherNet/IP, EtherCAT, PROFIBUS, PROFINET, DeviceNet, CANopen, POWERLINK
Control I/O	2 x analogue inputs, 2 x analog (or digital) outputs, 2 x digital I/O programmable, 6 x digital inputs (including 1 x frequency input, 1 x AB encoder input, 1 x PWM/frequency output, 1 x motor thermistor input), 1 x NO relay 250 Vac Max., 2 x OV common, 2 x 24V user output, 1 x 10V user output, 2 x Safe Torque Off (STO) inputs Additional I/O available with SI-I/O option module.
Accuracy	Frequency 0.02%, Analogue input 1: 11 bit plus sign, Analogue input 2: 11 bit. Current typical 2%.

On-Board user program capability	16kB
Keypad	Fixed LED keypad, Remote keypad with Real-time clock available as option
PC Tools	'Connect' commissioning and cloning tool including CT Oscilloscope, Machine Control Studio for On-board PLC programming.
Warranty	2 years
Supported options	AI-Back-up Adaptor, SI-SMART Adaptor, AI-485 & 24V Back-up Adaptor, RTC Remote Keypad, HMI, RS485-Communications lead, SI-EtherCAT, SI-PROFIBUS, SI-Ethernet, SI-DeviceNET, SI-CANopen, SI-PROFINET, SI-I/O, SI-Encoder (speed feedback), Remote I/O.
Accessories	Through-hole IP65 mounting kits (frame 5 to 9), UL type conduit kits, SK Retrofit mounting brackets, External EMC filters (standard and low leakage up to and including frame 4), Grounding bracket (supplied with the drive)

*Frames 1 to 4

DIMENSIONS

Frame Size	Overall Dimensions						Mounting Dimensions				Mounting Hole Diameter		Weight	
	mm			in			mm		in		mm	in	kg	lb
	H	W	D	H	W	D	H	W	H	W				
1	160	75	130	6.3	2.95	5.1	143	53	5.7	2.08	5	0.2	0.75	1.65
2	205	75	150	8.07	2.95	5.9	194	55	7.63	2.17	5	0.2	1.3	3
3	226	90	160	8.9	3.54	6.3	215	70.7	8.46	2.8	5	0.2	1.5	3.3
4	277	115	175	10.9	4.5	6.9	265	86	10.43	3.4	6	0.23	3.13	6.9
5	391	143	200	15.39	5.63	7.87	375	106	14.76	4.17	6.5	0.26	7.4	16.3
6	291	210	227	15.39	8.27	8.94	378	196	14.88	7.72	7	0.28	14	30.9
7	557	270	280	21.93	10.63	11.02	538	220	21.18	8.66	9	0.35	28	61.7
8	804	310	290	31.65	12.21	11.42	884	259	30.87	10.2	9	0.35	52	114.6
9A	1069	310	290	42.09	12.21	11.42	1051	259	41.38	10.2	9	0.35	46	101.4
9E	1108	310	290	43.62	12.21	11.42	1090	259	42.91	10.2	9	0.35	66.5	146.6



CONNECTIONS

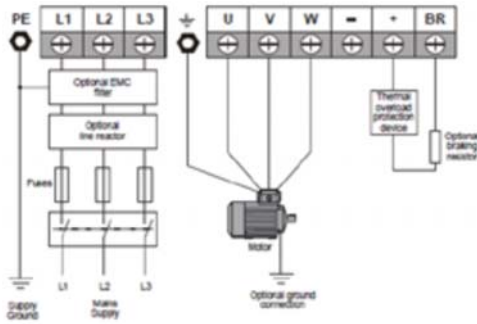

Typical Power Connections

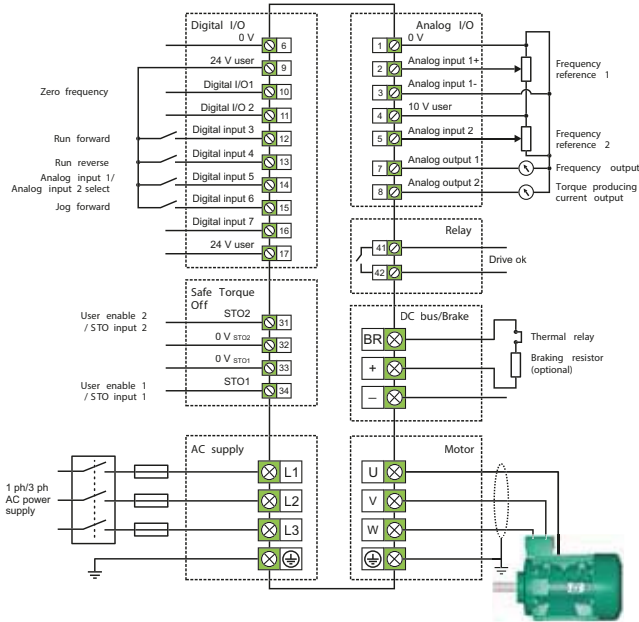

Default Control Connections

PRODUCT CODES

M400	03	4	0073	A	10100A	B	100
	Frame Size		Heavy Duty Current Rating x 10			B = Brake Transistor included N = No Brake Transistor	
Model: M400		Voltage Rating: 1 = 100V (100V-120V +/-10%) 2 = 200V (200V-240V +/-10%) 4 = 400V (380V-480V +/-10%) 5 = 575V (500V-575V +/-10%) 6 = 690V (500V-690V +/-10%)		Drive Format A = AC in AC out *E = AC in AC out, external choke required			

*Frame 9 only

MODEL NUMBER AND RATINGS

Product Codes	Frame Size	Supply Phases	Heavy Duty			Normal Duty		
			Max Cont. Current (A)	Motor Power (kW)	Motor Power (hp)	Max Cont. Current (A)	Motor Power (kW)	Motor Power (hp)
100V (100V-120V +/-10%)								
M400-01100017A	1	1	1.7	0.25	0.33			
M400-01100024A	1	1	2.4	0.37	0.5			
M400-01100042A	1	1	4.2	0.75	1			
M400-01100056A	1	1	5.6	1.1	1.5			
200V (200V-240 +/-10%)								
M400-01200017A	1	1	1.7	0.25	0.33			
M400-01200024A	1	1	2.4	0.37	0.50			
M400-01200033A	1	1	3.3	0.55	0.75			
M400-01200042A	1	1	4.2	0.75	1.0			
M400-02200024A	2	1/3	2.4	0.37	0.5			
M400-02200056A	2	1/3	3.3	0.55	0.75			
M400-02200056A	2	1/3	4.2	0.75	1.0			
M400-02200056A	2	1/3	5.6	1.1	1.5			
M400-02200056A	2	1/3	7.5	1.5	2.0			
M400-03200056A	3	1/3	10.0	2.2	3.0			
M400-04200056A	4	1/3	13.3	3.0	3.0			
M400-04200056A	4	3	17.6	4.0	5.0			
M400-05200056A	5	3	25.0	5.5	7.5	30	7.5	10
M400-06200056A	6	3	33.0	7.5	10.0	50	11.0	15
M400-06200056A	6	3	44.0	11.0	15.0	58	15.0	20
M400-07200056A	7	3	61.0	15.0	20.0	75	18.5	25
M400-07200056A	7	3	75.0	18.5	25.0	94	22.0	30
M400-07200056A	7	3	83.0	22.0	30.0	117	30.0	40
M400-08200056A	8	3	116.0	30.0	40.0	149	37.0	50
M400-08200056A	8	3	132.0	37.0	50.0	180	45	60
M400-09200056A/E	9	3	176.0	45.0	60.0	216	55	75
M400-09200056A/E	9	3	210.0	55.0	75.0	266	75	100

Heavy Duty rating only

Heavy Duty rating only

Model No.	Frame Size	Supply Phases	Heavy Duty			Normal Duty		
			Max Cont. Current (A)	Motor Power (kW)	Motor Power (hp)	Max Cont. Current (A)	Motor Power (kW)	Motor Power (hp)
400V (380V-480V +/-10%)								
M400-02400013A	2	3	1.3	0.37	0.5			
M400-02400018A	2	3	1.8	0.55	0.75			
M400-02400023A	2	3	2.3	0.75	1.0			
M400-02400032A	2	3	3.2	1.1	1.5			
M400-02400041A	2	3	4.1	1.5	2.0			
M400-03400056A	3	3	5.6	2.2	3.0			
M400-03400073A	3	3	7.3	3.0	3.0			
M400-03400094A	3	3	9.4	4.0	5.0			
M400-04400135A	4	3	13.5	5.5	7.5			
M400-04400170A	4	3	17.0	7.5	10.0			
M400-05400270A	5	3	27.0	11.0	20.0	30	15	20
M400-05400300A	5	3	30.0	15.0	20.0	31	15	20
M400-06400350A	6	3	35.0	15.0	25.0	38	18.5	25
M400-06400420A	6	3	42.0	18.5	30.0	48	22.0	30
M400-06400470A	6	3	47.0	22.0	30.0	63	30.0	50
M400-07400660A	7	3	66.0	30.0	50.0	79	37.0	60
M400-07400770A	7	3	77.0	37.0	60.0	94	45.0	75
M400-07401000A	7	3	100.0	45.0	75.0	112	55.0	75
M400-08401340A	8	3	134.0	55.0	100	155	75.0	100
M400-08401570A	8	3	157.0	75.0	125	184	90.0	125
M400-09402000A/E	9	3	200.0	90.0	150	221	110.0	150
M400-09402240A/E	9	3	224.0	110.0	150	266	132.0	200

Heavy Duty rating only

Model No.	Supply Phases	Heavy Duty			Normal Duty		
		Max Cont. Current (A)	Motor Power (kW)	Motor Power (hp)	Max Cont. Current (A)	Motor Power (kW)	Motor Power (hp)
500/575 Vac ±10 %							
M400-055 00030 A	3	3.0	1.5	2.0	3.9	2.2	3.0
M400-055 00040 A	3	4.0	2.2	3.0	6.1	4.0	5.0
M400-055 00069 A	3	6.9	4.0	5.0	10.0	5.5	7.5
M400-065 00100 A	3	10.0	5.5	7.5	12.0	7.5	10.0
M400-065 00150 A	3	15.0	7.5	10.0	17.0	11.0	15.0
M400-065 00190 A	3	19.0	11.0	15.0	22.0	15.0	20.0
M400-065 00230 A	3	23.0	15.0	20.0	27.0	18.5	25.0
M400-065 00290 A	3	29.0	18.5	25.0	34.0	22.0	30.0
M400-065 00350 A	3	35.0	22.0	30.0	43.0	30.0	40.0
M400-075 00440 A	3	44.0	30.0	40.0	53.0	37.0	50.0
M400-075 00550 A	3	55.0	37.0	50.0	73.0	45.0	60.0
M400-085 00630 A	3	63.0	45.0	60.0	86.0	55.0	75.0
M400-085 00860 A	3	86.0	55.0	75.0	108.0	75.0	100.0
M400-095 01040 A	3	104.0	75.0	100.0	125.0	90.0	125.0
M400-095 01310 A	3	131.0	90.0	125.0	150.0	110.0	150.0
500/690 Vac ±10 %							
M400-076 00190 A	3	19.0	15.0	20.0	23.0	18.5	25.0
M400-076 00240 A	3	24.0	18.5	25.0	30.0	22.0	30.0
M400-076 00290 A	3	29.0	22.0	30.0	36.0	30.0	40.0
M400-076 00380 A	3	38.0	30.0	40.0	46.0	37.0	50.0
M400-076 00440 A	3	44.0	37.0	50.0	52.0	45.0	60.0
M400-076 00540 A	3	54.0	45.0	60.0	73.0	55.0	75.0
M400-086 00630 A	3	63.0	55.0	75.0	86.0	75.0	100.0
M400-086 00860 A	3	86.0	75.0	100.0	108.0	90.0	125.0
M400-096 01040 A	3	104.0	90.0	125.0	125.0	110.0	150.0
M400-096 01310 A	3	131.0	110.0	150.0	150.0	132.0	175.0



Connect with us :



Visit us
WWW.UEM.CA

CONTACT US
1-877-670-3380

Email Us
INFO@UEM.CA